



United Technologies

Multinor[®] Chiller



Islands

Benefits at a glance



- Attractive ergonomic design
- Large branding surfaces for increased customer attention
- Optimal use of floor space provided by four lengths

Multinor[®] Chiller

Plug-in chiller island for promotional sales

Standard configuration

- Internal and external panels galvanized steel with hard-wearing NCS 0501-B58G white powder-coated finish
- Bumpers all around
- Electronic controller
- Temperature-assured forced-air cooling with air outlet
- Automatic defrost with drip water evaporation
- Natural refrigerant R290



Multinor 2030 G

Basic models

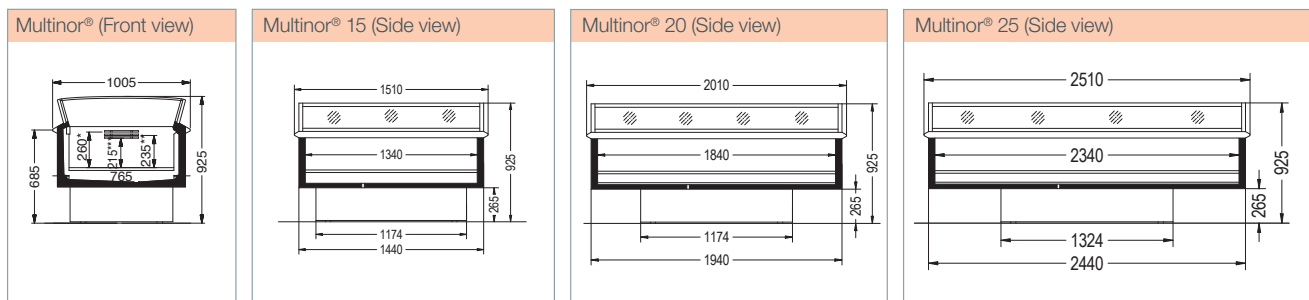

	Units	Natural						Standard								
		1540	2040	1531 G	2030 G	1550 G	2050 G	1531	2030	1540	2040	2540	1560 G	2060 G	2560 G	
Temperature	[°C]	0...+2		+2...+4		-1...+1		+2...+4		0...+2			-2...0			
Refrigerant		R290						R404A								
Width	[mm]	1005						1005								
Depth	[mm]	1510	2010	1510	2010	1510	2010	1510	2010	1510	2010	2510	1510	2010	2510	
Height	[mm]	925		945		945		925		925			945			
Volume	[l]	242	331	288	366	268	366	288	366	242	331	421	268	366	465	
Power cons. ref.	[W]	355	419	240	271	276	297	370	490	370	490	650	350	450	580	
Power cons. def.	[W]	755	815	396	480	785	900	55	55	980	980	990	1020	1040	1050	
Energy consumption*	[kWh/d]	3.9	4.8	3.3	4.3	4.9	5.4	4.7	5.0	6.4	8.1	8.8	5.5	7.0	8.0	
Heat dispatch*	[W]	163	200	138	179	204	225	196	208	267	338	367	229	292	333	
Application																

* at Climate Class 3 according to ISO 23953



Carrier Commercial Refrigeration is a leading supplier of high-efficiency turnkey refrigeration systems and services in the food retail industry.

www.carrier-refrigeration.com
www.carrier.com

