



United Technologies

Crystal COC90, COC95



Semi verticals

Benefits at a glance



- High product visibility and good promotion for increased impulse sales
- Ideal for beverages and convenience food
- Products are accessible at the ideal grab level
- Shelves or tiered steps allow flexible promotion

Crystal COC90, COC95

Small plug-in semi-vertical for promotional sales

Standard configuration

- Temperature-assured forced-air cooling with honeycomb air outlet
- Mechanical thermostat (COC90), electronic controller (COC95)
- Internal and external panels galvanized steel with hard-wearing white powder-coated finish
- Full glazed endwalls
- Metal shelves
- Horizontal lighting T8 for COC95



Crystal COC90

Basic models

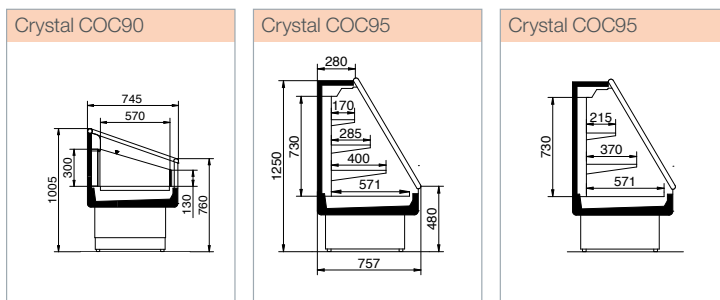

Crystal COC95

| | Units | COC90 | COC95 |
|------------------------|---------|---------|-------|
| Temperature | [°C] | +2...+4 | |
| Refrigerant | | R134a | |
| Width | [mm] | 897 | |
| Depth | [mm] | 745 | 757 |
| Height | [mm] | 1005 | 1250 |
| Volume | [l] | 98 | 175 |
| Power consumption ref. | [W] | 325 | 720 |
| Power consumption def. | [W] | 350 | 225 |
| Energy consumption* | [kWh/d] | 7.0 | 11.0 |
| Heat dispatch* | [W] | 290 | 460 |
| Application | | | |

* at Climate Class 3 according to ISO 23953



Carrier Commercial Refrigeration is a leading supplier of high-efficiency turnkey refrigeration systems and services in the food retail industry.

www.carrier-refrigeration.com
www.carrier.com

