

CRPWREXH028A01,
 CRPWREXH029A01,
 CRPWREXH082A00,
 CRPWREXH083A00
 For Use With Horizontal
 EconoMiSer IV, EconoMiSer 2,
 or EconoMiSer X (W7220)

**SMALL ROOFTOP UNITS
 ACCESSORY HORIZONTAL POWER EXHAUST
 GAS HEATING/ELECTRIC COOLING, ELECTRIC
 COOLING, AND HEAT PUMP UNITS
 3 TO 15 TON
 SIZES 04-016, 036-180**

Installation Instructions

TABLE OF CONTENTS

PACKAGE CONTENTS.....	1
PACKAGE USAGE.....	1
SAFETY CONSIDERATIONS.....	1
GENERAL.....	1
INSTALLATION.....	2-11
Power Exhaust Wiring with ECONOMISER IV and ECONOMISER X.....	4
Power Exhaust Wiring with EconoMiSer 2 and PremierLink™ Control or RTU-MP/OPEN.....	9
Operational Notes for Testing Purposes— PremierLink.....	10
Attaching Power Exhaust to Duct.....	11

IMPORTANT: Read these instructions completely before attempting to install this accessory.

PACKAGE CONTENTS

QTY	CONTENTS
1	Power Exhaust Hood/Fan Assembly
1	Low Voltage Wiring Harness with plug — 48 in. (1219mm)
1	High Voltage Wiring Harness with plug — 218 in. (5537mm)
8	No. 10 x 3/4 in. (19mm) Mounting Screws

UNIT CONFIGURATION TABLE

UNIT CONFIGURATION	UNIT FOOTPRINT SIZE
Small Cabinet	46 3/4" x 74 3/8"
Large Cabinet	58 1/2" x 88 1/8"
Extra Large Cabinet	63 3/8" x 115 7/8"

PACKAGE USAGE

UNIT SIZE	UNIT VOLTAGE	No. of FANS	POWER EXHAUST PART NUMBER
Small and Large Cabinet	208/230 V, 1 Ph	1	CRPWREXH028A01
	460 V, 3 Ph	1	CRPWREXH029A01
Extra Large Cabinet	208/230 V, 1 Ph	2	CRPWREXH082A00
	460 V, 3 Ph	2	CRPWREXH083A00

SAFETY CONSIDERATIONS

Installation and servicing of air-conditioning equipment can be hazardous due to system pressure and electrical components. Only trained and qualified service personnel should install, repair, or service air-conditioning equipment.

Untrained personnel can perform the basic maintenance functions of replacing filters. All other operations should be performed by trained service personnel. When working on air-conditioning equipment, observe precautions in the literature, tags, and labels attached to the unit, and other safety precautions that may apply.

Follow all safety codes. Wear safety glasses and work gloves.

Recognize safety information. This is the safety-alert symbol . When you see this symbol on the unit and in instructions or manuals, be alert to the potential for personal injury.

Understand these signal words; DANGER, WARNING, and CAUTION. These words are used with the safety-alert symbol. DANGER identifies the most serious hazards which **will** result in severe personal injury or death. WARNING signifies hazards which **could** result in personal injury or death. CAUTION is used to identify unsafe practices which **may** result in minor personal injury or product and property damage. NOTE is used to highlight suggestions which will result in enhanced installation, reliability, or operation.

WARNING

ELECTRICAL SHOCK HAZARD

Failure to follow this warning could cause personal injury and/or death.

Before beginning any modification, be certain that the main-line electrical disconnect switch is in the OFF position. Close the main gas supply shutoff valve. Tag disconnect switch and gas valve with suitable warning labels.

⚠ CAUTION

CUT HAZARD

Failure to follow this caution may result in personal injury. Sheet metal parts may have sharp edges or burrs. Use care and wear appropriate protective clothing, safety glasses and gloves when handling parts and servicing furnace.

GENERAL

The accessory horizontal power exhaust is used in conjunction with horizontal EconoMiSer IV, EconoMiSer X, or EconoMiSer2 only and is mounted external to the rooftop unit in the return air ductwork. For vertical return air applications, this power exhaust accessory **cannot** be used. The vertical power exhaust accessory must be used for vertical return air applications.

NOTE: This accessory may be used with the horizontal or vertical EconoMiSer.

See Table 1 and 2 for EconoMiSer usage. See Fig. 1 for accessory dimensions. The 028, 029 accessory weighs 30 lb (13.6 kg). The 082, 083 accessory weighs 75 lb (34 kg).

NOTE: For 575-v installations, a field-supplied and installed transformer (part no. HT01AH859) must be used with 208/230 v power exhaust.

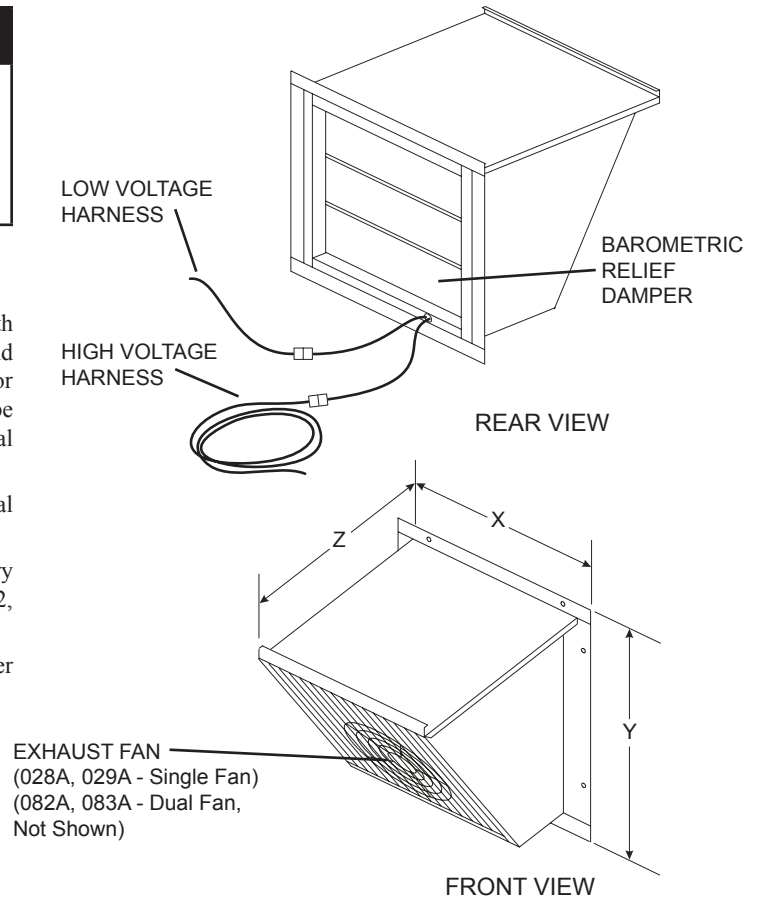

Power Exhaust	"X" in (mm)	"Y" in (mm)	"Z" in (mm)
CRPWREXH028A01	23.25 (590)	24.3 (625)	19.6 (495)
CRPWREXH029A01			
CRPWREXH082A00	39 (990)	24.3 (625)	17.1 (435)
CRPWREXH083A00			

Fig 1 - Accessory Horizontal Power Exhaust

Table 1 - Accessory Horizontal EconoMiSer Usage

PART NO.	UNIT SIZE	DESCRIPTION
CRECOMZR024A02	Small Cabinet	EconoMiSer IV with W7212 Controller
CRECOMZR025A02	Large Cabinet	
CRECOMZR064A00	Extra Large Cabinet	
CRECOMZR026A00	Small Cabinet	EconoMiSer2 without Controller (for use with PremierLink controller or field-supplied building management system).
CRECOMZR027A00	Large Cabinet	
CRECOMZR065A00	Extra Large Cabinet	

NOTE: Power Exhaust can also be used with horizontal economizers with the W7220 controller (EconoMiSer X)

Table 2 - Horizontal EconoMiSer Usage

BASE RTU UNIT SERIAL #	DESCRIPTION
From 4005Gxxxxx to current	EconoMiSer IV with W7212 controller.
From 0802Gxxxxx to current	EconoMiSer2 without controller (used with PremierLink or field-supplied building management system).

INSTALLATION

IMPORTANT: Follow all local and national electrical codes when installing accessory.

Follow all local and NEC (National Electrical Code) codes. If a single power source is to be used, size the wire to include power exhaust MCA and MOCP. (See Table 3.)

Table 3 - Power Exhaust Electrical Data

POWER EXHAUST PART NO.	MCA (230 v)	MCA (460 v)	MCA (575 v)	MOCP (for separate power source)
CRPWREXH028A01	1.7	N/A	0.68	15
CRPWREXH029A01	N/A	1.0	N/A	15
CRPWREXH082A00	3.3	N/A	1.32	15
CRPWREXH083A00	N/A	1.8	N/A	15

LEGEND

MCA --- Minimum Circuit Amps

MOCP --- Maximum Overcurrent Protection

N/A --- Not Applicable

NOTE: For R--410A units, refer to unit nameplate for MCA and MOCP for installed power exhaust. For R--22 units, use the calculations detailed below. If multiple power exhausts are used, the MCA value used in wire size calculations must be the sum of the number of individual power exhausts used.

Check MCA and MOCP when power exhaust is powered through the unit (must be in accordance with NEC and/or local codes). Determine the new MCA including the power exhaust using the following formula:

$$MCA\ New = MCA\ unit\ only + MCA\ of\ Power\ Exhaust$$

For example, using a R--22 gas heat, electric cooling, 6--ton unit with MCA = 28.9 and MOCP = 35, with CRPWREXH030A01 power exhaust.

$$MCA\ New = 28.9\ amps + 1.7\ amps = 30.6\ amps$$

If the new MCA does not exceed the published MOCP, then MOCP would not change. The MOCP in this example is 35 amps, the MCA New is below 35, therefore the MOCP is acceptable. If "MCA New" is larger than the published MOCP, raise the MOCP to the next larger size.

For separate power, the MOCP for the power exhaust will be 15 amps per NEC.

NOTE: For 575--v installations, a field--supplied and installed transformer (part no. HT01AH859) must be used with 208/230--v power exhaust. See Fig. 5 for single fan units and Fig. 7 for dual fan units.

The horizontal power exhaust can be used with 3 different types of EconoMi\$ers. These instructions will clearly describe the installation and wiring for:

- EconoMi\$er IV with W7212 controller.
- EconoMi\$er X with W7220 controller.
- EconoMi\$er2 without controller (used with PremierLink controller or a field-supplied building management system).

To install the horizontal power exhaust, perform the following procedure:

1. Turn off unit power supply and install lockout tag.

⚠ WARNING

ELECTRICAL SHOCK HAZARD
 Failure to follow this warning could cause personal injury and/or death.

Before beginning any modification, be certain that the main-line electrical disconnect switch is in the OFF position. Close the main gas supply shutoff valve. Tag disconnect switch and gas valve with suitable warning labels.

2. If ductwork has not already been constructed and connected to HVAC (heating, ventilation and air conditioning) unit, field-fabricate and secure the return air duct per HVAC unit recommendations and the unit installation instructions.
3. Once the horizontal EconoMi\$er has been installed, locate the notched tab in the upper left corner of the return damper. (See Fig. 2.) Bend back this tab to allow for power exhaust wiring entry.

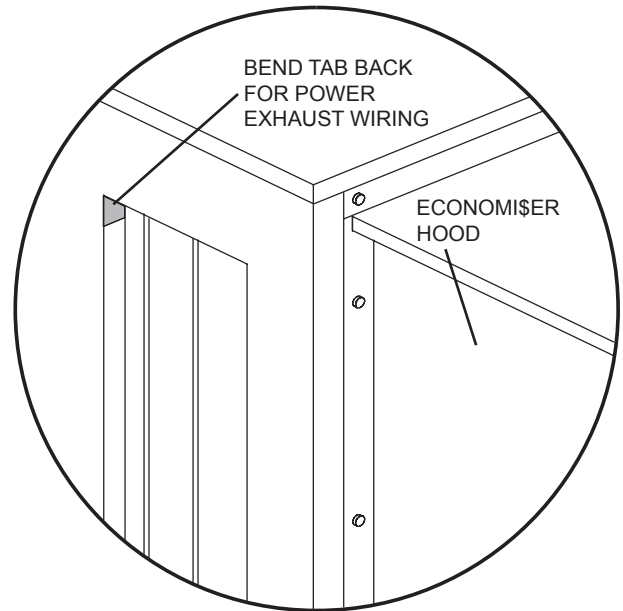

C07419

Fig. 2 - Tab on Horizontal EconoMi\$er

4. Install the EconoMi\$er per the instructions provided with the accessory. Tape the barometric relief blades on the EconoMi\$er shut. The barometric relief is not used when the power exhaust is installed.
5. Cut an exhaust air opening in the side of the return air duct. See Fig. 3 for dimensions.
6. Place the power exhaust near the exhaust air opening in preparation for wiring to the unit. It may be easier to hold the power exhaust unit up to this opening and attach with a few screws and then remove so that the installation will be easier later when it is important that the wires are not pinched.

Power Exhaust Wiring for EconoMiSer IV and EconoMiSer X

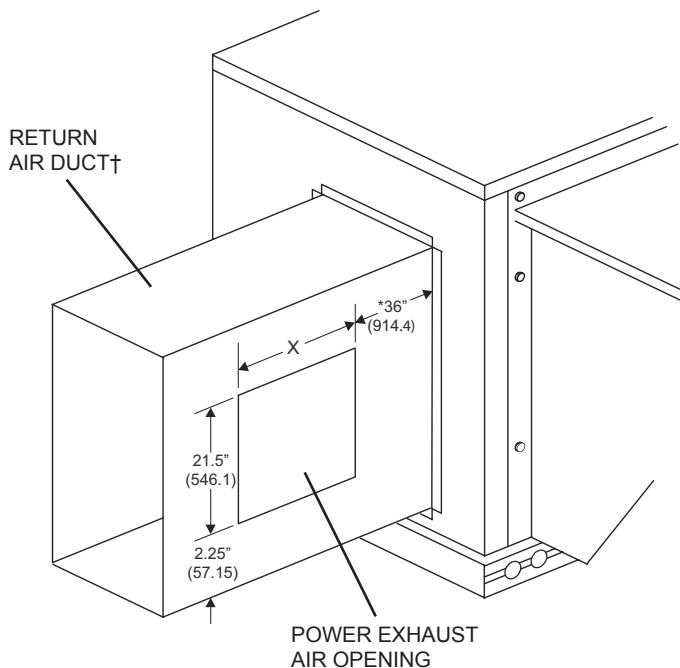

Power Exhaust	"X" in (mm)
CRPWREXH028A01	19.5 (495)
CRPWREXH029A01	
CRPWREXH082A00	35 (890)
CRPWREXH083A00	

NOTES:

Dimensions are in inches. Dimensions in () are in millimeters.

* Recommended distance if space allows.

† May require bracing due to the weight of the power exhaust.

Fig. 3 - Tab on Horizontal EconoMiSer

- Follow control and power wiring instructions specific to this economizer and unit control.

IMPORTANT: To achieve higher levels of exhaust air, multiple power exhaust accessories may be used. If more than one power exhaust is being installed, cut additional openings in the ductwork.

- Both wiring harnesses (low voltage and high voltage) are plugged together with the extensions at the factory for shipping. Unplug harnesses and uncoil wire. (See Fig. 1.)
- For EconoMiSer IV: Route the other end of the low voltage extension harness to the EconoMiSer controller. (See Fig. 4.) The harness is connected to the controller by connecting the tan wire to the tan wire 24 VAC COM terminal on the controller. The terminal on the gray wire is connected to terminal EF1 on the controller. See Fig. 5 – Fig. 8 for EconoMiSer wiring diagrams. Install the gray jumper wire on the controller from the exhaust fan terminal (EF), to the 24 VAC HOT terminals. The gray jumper is shipped wire tied to the control harness.

For EconoMiSer type with W7220 controller: Route the end of the low voltage extension harness to the EconoMiSer X 12 pin plug (PL6). The gray wire harness connects to the yellow wire coming from terminal 8 in the 12 pin plug. The tan wire from the low voltage extension harness connects to the brown wire coming from terminal 4 in the 12 pin plug. See figures 5-8 for wiring diagrams.

- The power line wiring harness must be routed through the duct, through the hole created by the bent tab on the EconoMiSer, and through the unit to the control box. (See Fig. 4.) The harness must be routed through the grommets provided in the unit control box. Do not drill routing holes.
- Wire the end of the power line wiring harness to the power exhaust power source. (See Fig. 5 – Fig. 8.) **R-410A Rooftop Models Only:** For single point wiring applications, connect the power exhaust power wire harness to the compressor contactor in the control box. Install the power exhaust power wire harness into the pressure lugs on the compressor contactor, used for the field power wiring also. Be careful not to route power exhaust harness on top of indoor coil. Follow all local and NEC (National Electrical Code) codes. If a single power source is to be used, size the wire to include power exhaust MCA and MOCP.
- Make sure all wiring is secure. Use field-supplied wire ties if necessary. Be sure that wiring does not interfere with operation of the HVAC unit, EconoMiSer, or power exhaust.
- Connect the low voltage harness plug and the power line harness plug to the two plugs coming out of the power exhaust. (See Fig. 4.)

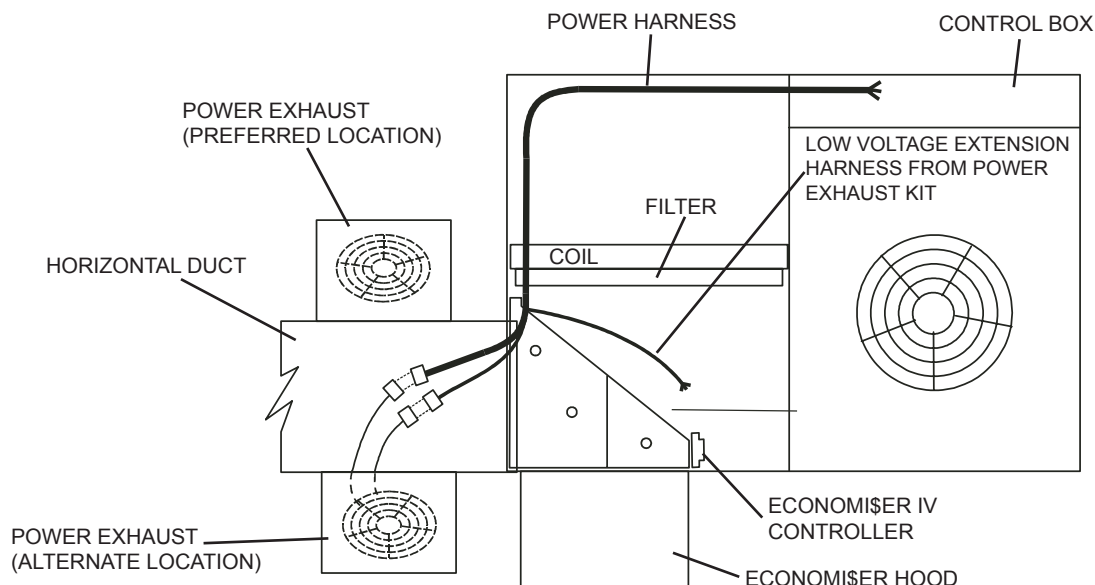
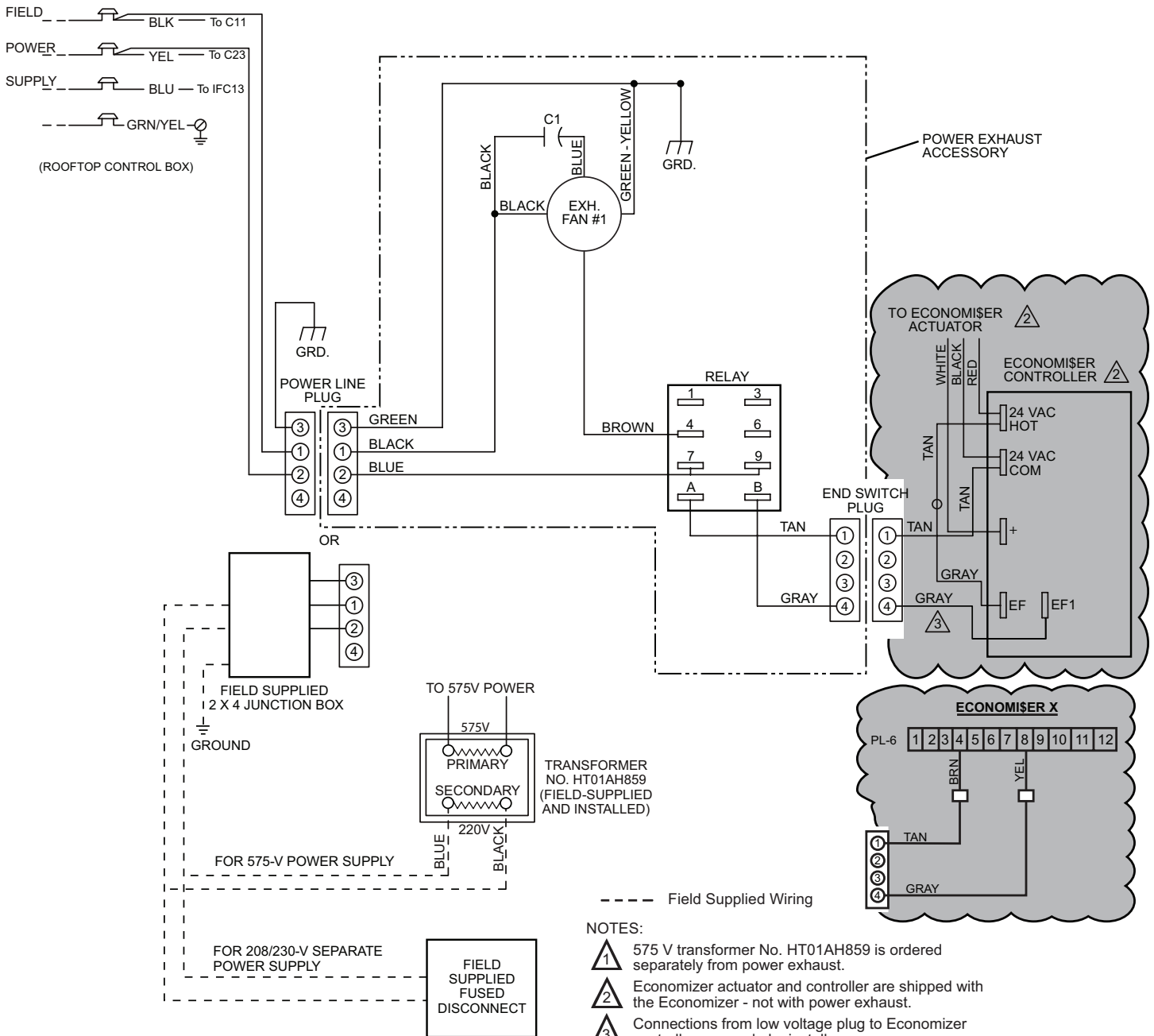

Fig. 4 - Power Exhaust Harness Routing for EconoMiSer IV and EconoMiSer X



- Field Supplied Wiring
- NOTES:
- ① 575 V transformer No. HT01AH859 is ordered separately from power exhaust.
 - ② Economizer actuator and controller are shipped with the Economizer - not with power exhaust.
 - ③ Connections from low voltage plug to Economizer controller are made by installer.
 - ④ If a single power source is to be used, size wire to include power exhaust MCA and MOCP.
- For R-410A units, refer to unit nameplate for MCA and MOCP for installed power exhaust.
- For R-22 units, use the following calculations
- Check MCA and MOCP when power exhaust is powered through the unit. Determine the new MCA including the power exhaust using the following formula:
- MCA New = MCA unit only + MCA of Power Exhaust
- For example, using an electric cooling, 6-ton R-22 unit with MCA + 28.9 and MOCP = 35, with CRPWREXH030A01 power exhaust.
- MCA New = 28.9 amps + 1.5 amps = 30.4 amps
- If the new MCA does not go over the MOCP published, then MOCP would not change. The MOCP in this example is 35 amps, the MCA New is below 35, therefore the MOCP is OK. If "MCA New" is larger than the published MOCP, raise the MOCP to the next larger size. For separate power, the MOCP for the power exhaust will be 15 amps per NEC.

C10543

Fig. 5 - Single Fan Power Exhaust Wiring for EconoMiSer IV and EconoMiSer X - 208/230 and 575 V Units

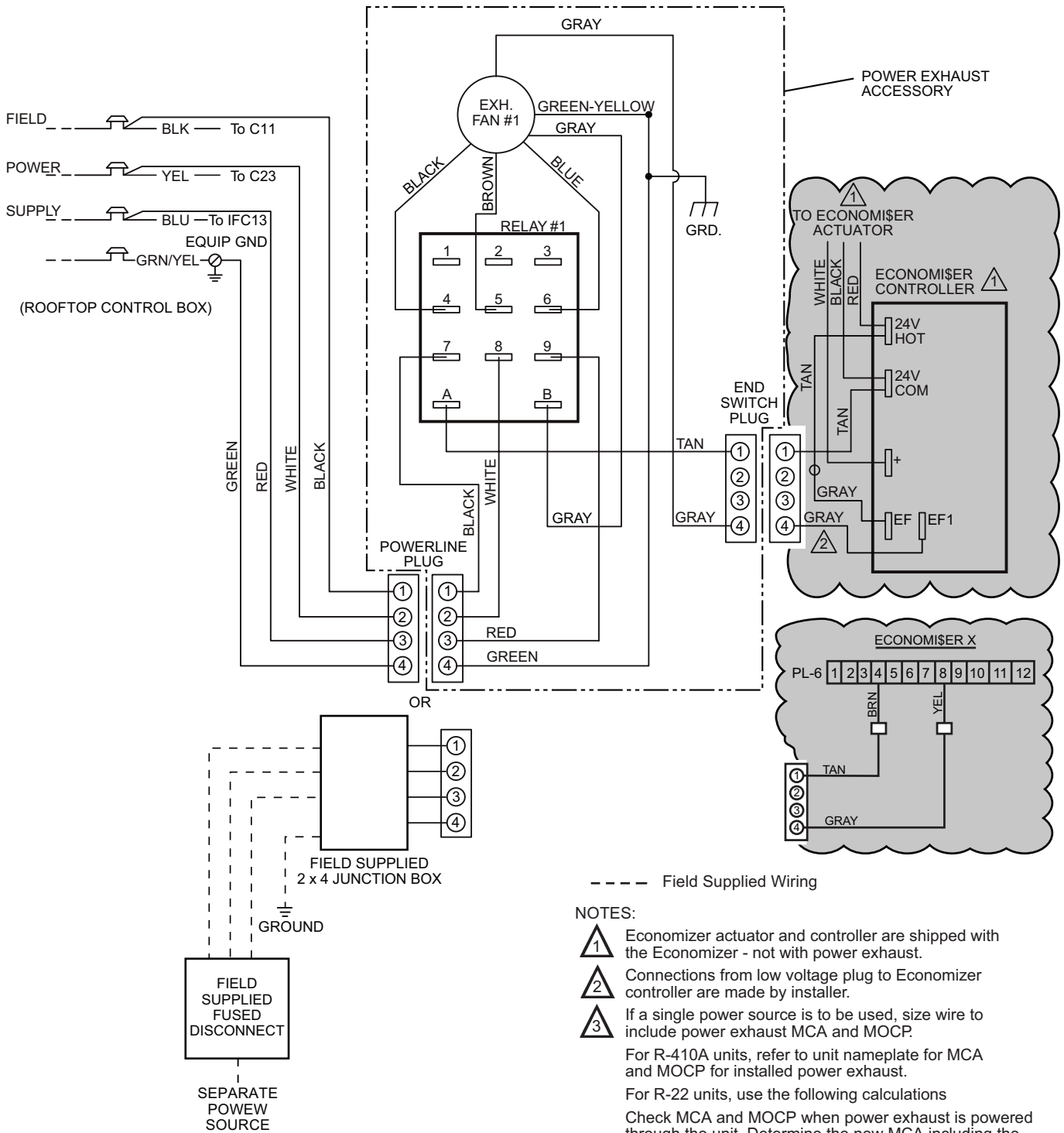

C10544

Fig. 6 - Single Fan Power Exhaust Wiring for EconoMiSer IV and EconoMiSer X - 460 V Units

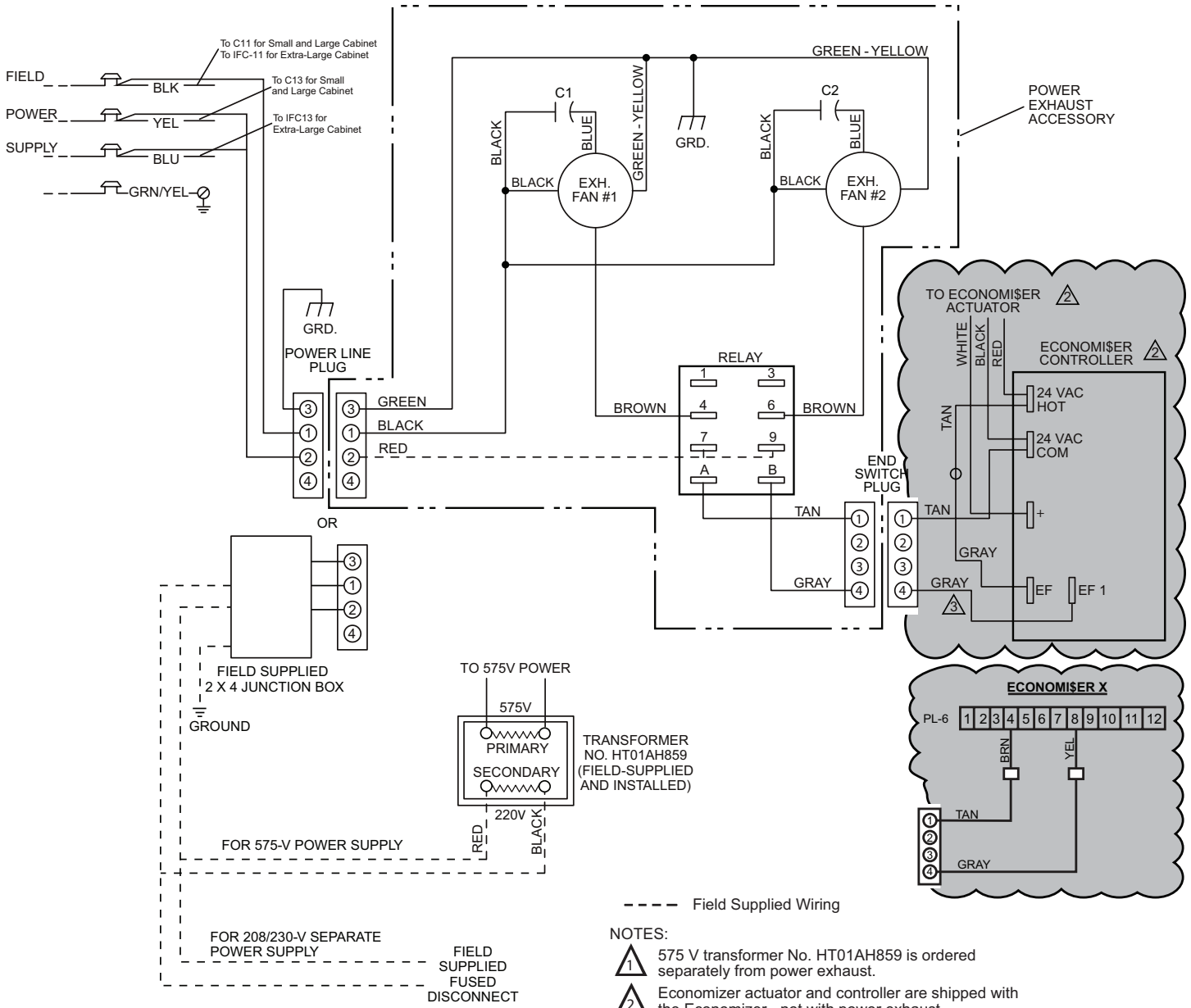
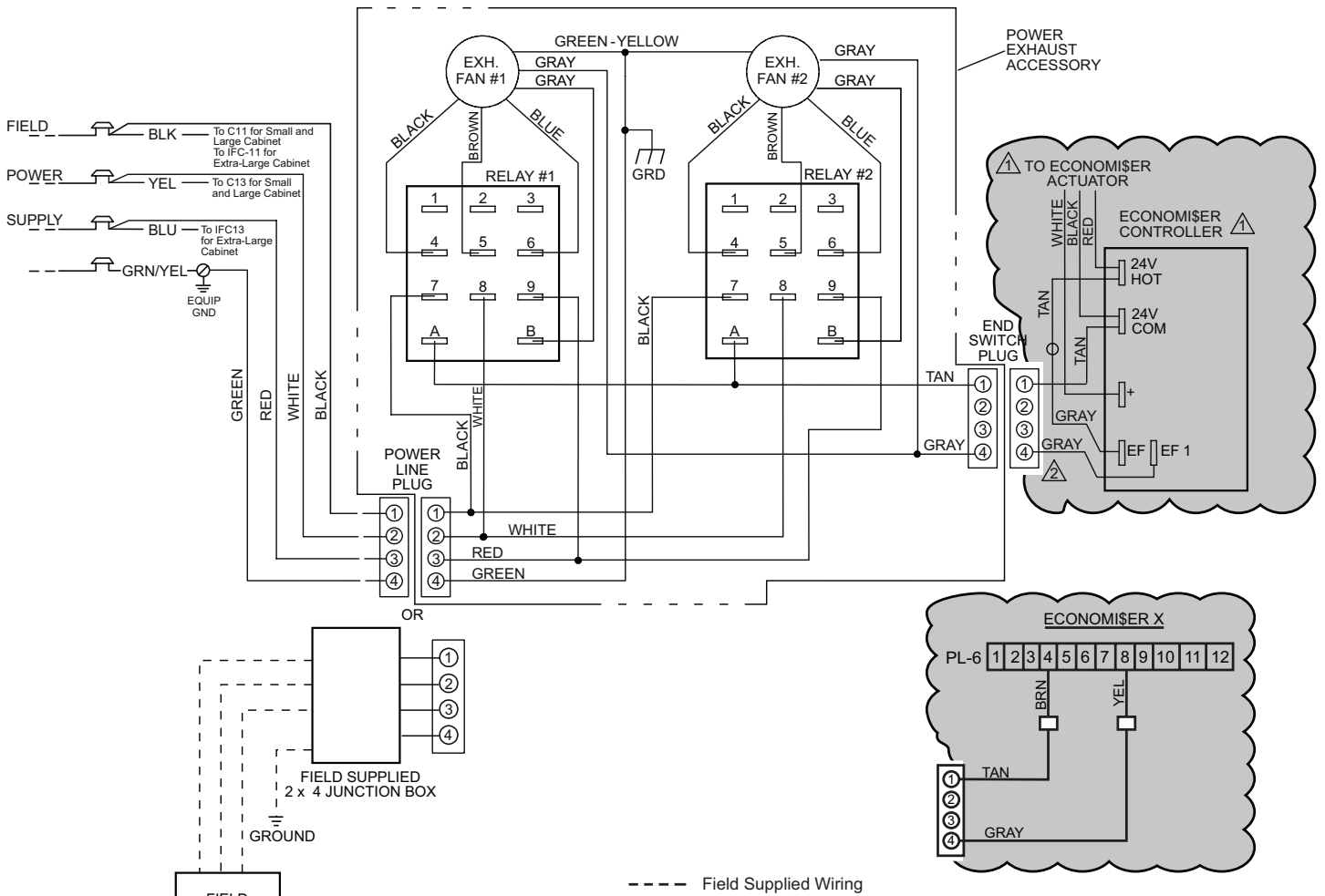

Fig. 7 - Dual Fan Power Exhaust Wiring for EconoMiSer IV and EconoMiSer X - 208/230 V and 575 V Units

C10426



NOTES:

- 1. Economiser actuator and controller are shipped with the Economiser not with power exhaust.
- 2. Connections from low voltage Plug to the Economiser controller are made by installer.
- 3. If a single power source is to be used, size wire to include power exhaust MCA and MOCP.
 For R-410A units, refer to the unit nameplate for MCA and MOCP for installed power exhaust.
 For R-22 units use the following calculations
 Check MCA and MOCP when power exhaust is powered through the unit. Determine the new MCA including the power exhaust using the following formula:
 $MCA\ New = MCA\ unit\ only + MCA\ of\ Power\ Exhaust$
 For example, using an electric cooling, 6-ton R-22 unit with MCA = 28.9 and MOCP = 35, with CRPWREXH030A01 power exhaust.
 $MCA\ New = 28.9\ amps + 1.5\ amps = 30.4\ amps$
 If the new MCA does not go over the MOCP published, then MOCP would not change. The MOCP in this example is 35 amps, the MCA New is below 35, therefore the MOCP is OK. If "MCA NEW" is larger than the published MOCP, raise the MOCP to the next larger size. For separate power, the MOCP for the power exhaust will be 15 amps per NEC.

C10427

Fig. 8 - Dual Fan Power Exhaust Wiring for EconoMiSer IV and EconoMiSer X - 460 V Units

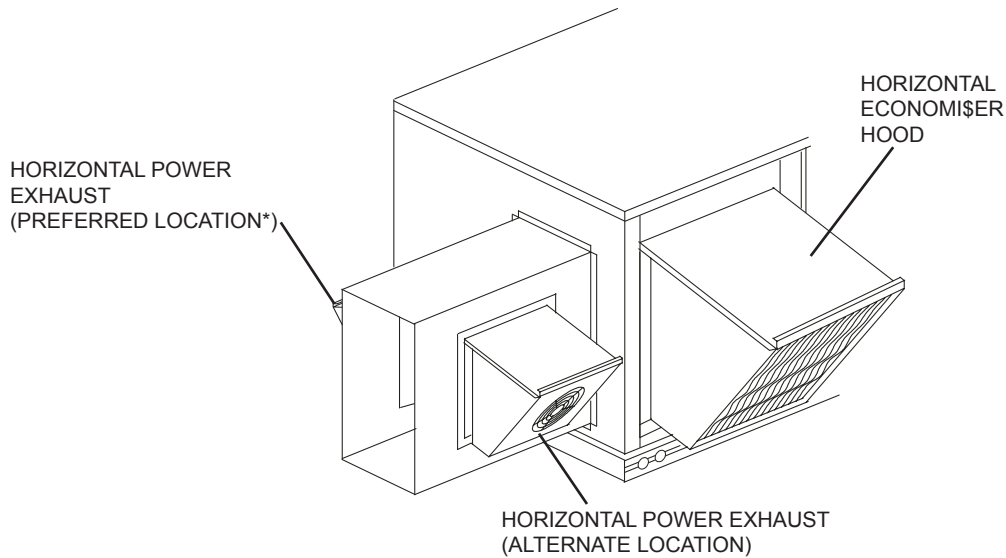

* Use alternate location if preferred location causes recirculation of exhaust air into outdoor air intake.

Fig. 9 - Power Exhaust Installed in Duct

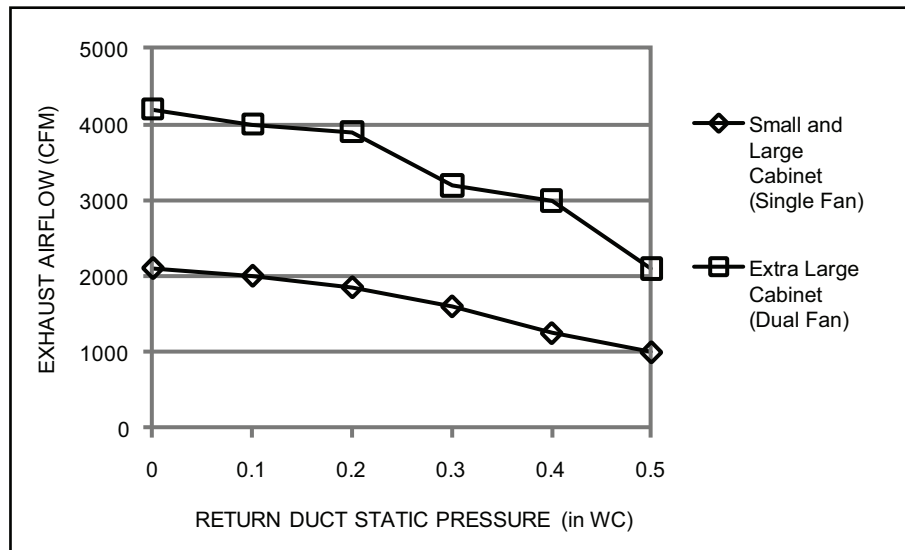

Fig. 10 - Power Exhaust Performance

Power Exhaust Wiring with EconoMiSer2, Comfortlink and PremierLink Controller or RTU--MP/OPEN

Use these instructions when installing the vertical power exhaust with EconoMiSer2 and PremierLink or RTU--MP/OPEN controller.

1. A low voltage extension harness is supplied with the EconoMiSer2 (without controller).
2. Both the low voltage and power harness must be run through the duct, through the hole created by the bent tab on the EconoMiSer2, and through the unit control box. (See Fig. 9.)
3. Run the low voltage harness extension to the PremierLink control.

4. Route the other end of the long high voltage extension harness through the HVAC unit to the control box. (See Fig. 4.) The harness must be routed through the grommets provided in the unit. Do not drill routing holes. Be careful not to route the power exhaust harness on top of the indoor coil.

5. Wire the end of the power line wiring harness to the power exhaust power source. (See Fig. 5 -- Fig. 8.)

R-410A Rooftop Models Only:

For single point wiring applications, connect the power exhaust power wire harness to the compressor contactor in the control box. Install the power exhaust power wire harness into the pressure lugs on the compressor contactor, used for the field power wiring also. Follow all local and NEC (National Electrical Code) codes. If a single power source is to be used, size the wire to include power exhaust MCA and MOCP. (See Table 3.)

6. **Field--Installed PremierLink Control** (See Fig. 12)
 Connect the gray wire from the low voltage extension harness to J8--3 and the tan wire to common terminal. Common is available from PremierLink terminal J1 or the common side of the unit control power transformer (the brown leads that go to unit ground). The other end of the harness is connected to the power exhaust wiring.

NOTE: When the PremierLink board is configured for a heat pump, it does not require the HS3/EXH/RVS, allowing this terminal to be used for the power exhaust.

Factory--Installed PremierLink Control

The PremierLink J8--3 terminal is factory wired to a terminal board TB2--15 (Small & Large Cabinet) or TB3--15 (Extra Large Cabinet) located in the low voltage section to the left of the control box. The gray wire from the harness should be routed and wired to TB2--15 or TB3--15. The tan wire should be routed and wired to the Central Terminal Board Thermostat Terminal C (Common).

RTU--MP/OPEN Control

Connect the gray wire from the low voltage harness extension to J11--3 and the tan wire to the Central Terminal Board Thermostat Terminal C (Common).

Comfortlink Control

Connect the gray wire from the low voltage harness extension to the loose red wire from the Economizer Control Board (EBC). Connect the tan wire to the loose tan wire from PL7.

7. Make sure all wiring is secure. Use field-supplied wire ties if necessary. Be sure that wiring does not interfere with operation of the HVAC unit, EconoMiSer, or power exhaust.

8. Connect the low voltage harness plug and the power line harness plug to the two plugs coming out of the power exhaust. (See Fig. 9.)

**Operational Notes For Testing Purposes—
 PremierLink**

If the “continuous power exhaust” function is disabled, the power exhaust fan will operate during EconoMiSer purge cycles when the EconoMiSer damper position is above the configured minimum value. If enabled, the power exhaust fan will follow the supply fan’s operation for PremierLink version 1.2 and will follow the occupancy configuration for PremierLink version 1.3.

The PremierLink “Auxiliary Output” function defines the specific use of the auxiliary output (HS3/EXH/RVS) for the power exhaust. The output will be energized or deenergized by the appropriate algorithm that uses that specific output. A setting of 1 = Exhaust fan output.

The Power Exhaust set point in the set point table determines the power exhaust damper “percent open” when the power exhaust is energized. The damper percentage set point has a 10% hysteresis.

If “Continuous” in the service configuration table is set to “enable”, the power exhaust output will energize when occupied (for PremierLink controls version 1.3 and later) and will be energized when the supply fan relay is on (for versions prior than 1.3).

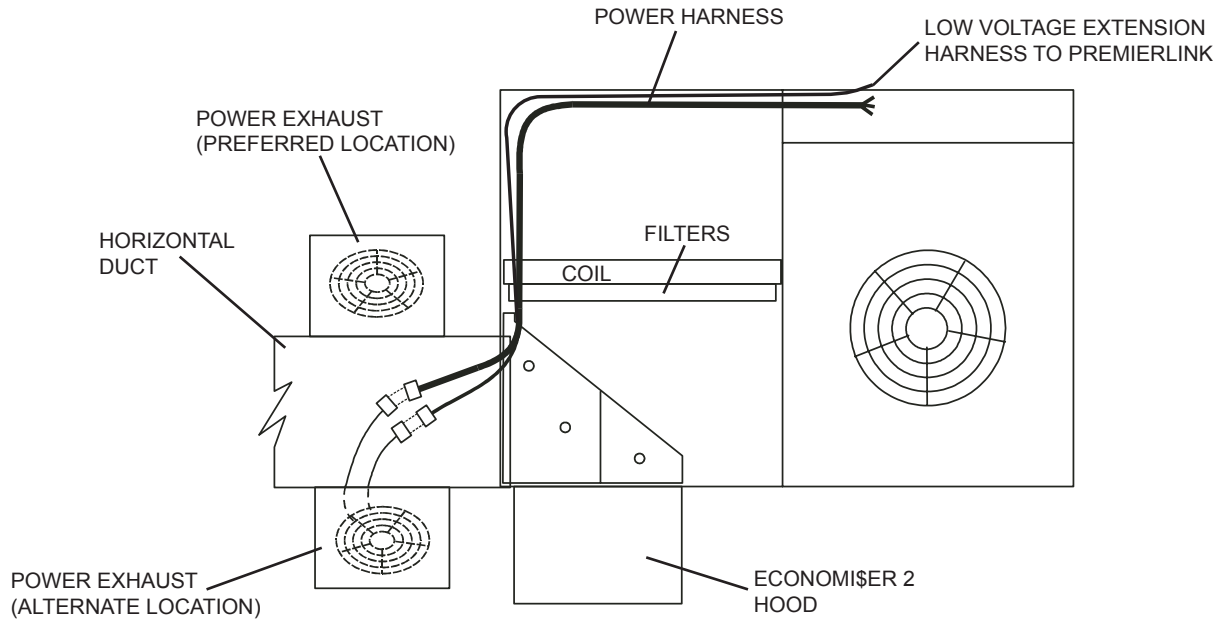

C07424

**Fig. 11 - Harness Routing for EconoMiSer with PremierLink Controls
 (R-22 Equipped Models)**

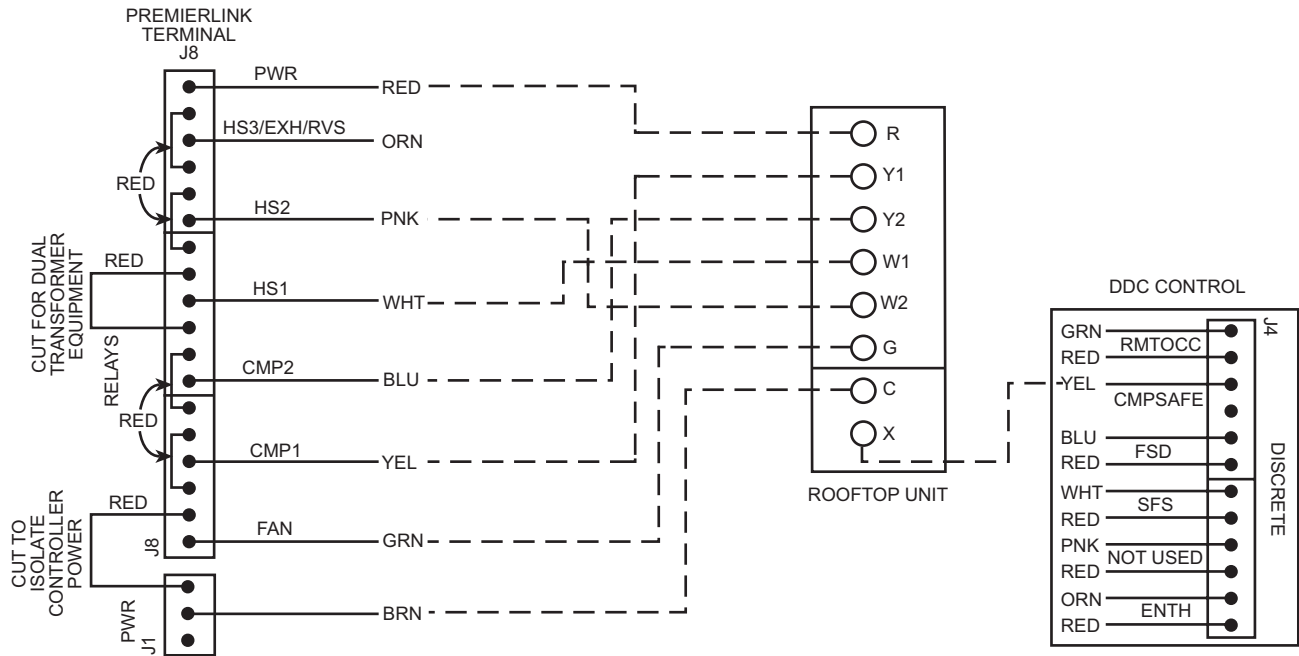

C07491

Fig. 12 - Typical PremierLink Control Wiring To R-22 Equipped Rooftop Units

Attaching Power Exhaust to Duct

1. Caulk the side mating flanges on the power exhaust. Lift power exhaust and install over the duct opening using the screws (no. 10 x 3/4 in.) provided. (See Fig. 9.) Make sure wiring harnesses are properly secured.

IMPORTANT: The return air duct will need to support the weight of the power exhaust. Reinforce or support duct properly to prevent damage to duct from the weight of the power exhaust.

1. Adjust the power exhaust set point on the EconoMi\$er controller to the desired activation point.
2. Return power to unit and remove lockout tag.
3. Test power exhaust operation by setting the power exhaust set point on the EconoMi\$er controller to 0%. Power exhaust performance is shown in Fig. 10.

