

Installation Instructions

The accessory temperature sensor can be used on all rooftop units with a factory-installed or accessory EconomiSer IV,

PACKAGE CONTENTS

QTY	CONTENTS
1	Temperature Sensor
2	6-20, 3/4 in. Sheet Metal Screw
1	Grommet
1	Black Wire
1	Red Wire

IMPORTANT: Read these instructions completely before attempting to install the accessory temperature sensor.

SAFETY CONSIDERATIONS

Installation and servicing of air-conditioning equipment can be hazardous due to system pressure and electrical components. Only trained and qualified service personnel should install, repair, or service air-conditioning equipment.

Untrained personnel can perform the basic maintenance functions of replacing filters. All other operations should be performed by trained service personnel. When working on air-conditioning equipment, observe precautions in the literature, tags, and labels attached to the unit, and other safety precautions that may apply.

Follow all safety codes. Wear safety glasses and work gloves. Have fire extinguishers available for all brazing operations.

Recognize safety information. This is the safety-alert symbol .

When you see this symbol on the unit and in instructions or manuals, be alert to the potential for personal injury.

Understand the signal words DANGER, WARNING, and CAUTION. These words are used with the safety-alert symbol. DANGER identifies the most serious hazards which **will** result in severe personal injury or death. WARNING signifies a hazard which **could** result in personal injury or death. CAUTION is used to identify unsafe practices which **may** result in minor personal injury or product and property damage. NOTE is used to highlight suggestions which **will** result in enhanced installation, reliability, or operation.

WARNING

ELECTRICAL SHOCK HAZARD

Failure to follow this warning could cause personal injury and/or death.

Disconnect power supply and install lockout tag before attempting to install the accessory.

GENERAL

Units with factory-installed enthalpy sensor can be changed to outdoor dry bulb changeover control with a single accessory temperature sensor. All other units come with the dry bulb sensor as standard with the factory-installed EconomiSer IV. The sensor is used for outdoor temperature control.

Outdoor Dry Bulb Changeover Control

For this control mode, the outdoor temperature is compared to an adjustable set point selected on the sensor. If the outdoor air temperature is above the set point, the EconomiSer IV will adjust the outdoor air dampers to minimum position. If the outdoor air temperature is below the set point, the position of the outdoor air dampers will be controlled to provide free cooling using outdoor air.

GENERAL INSTALLATION

NOTE: This section assumes you are starting with an EconomiSer IV installed in the rooftop and equipped with a single enthalpy sensor (p/n HH57AC078). If your EconomiSer is already equipped with a dry bulb temperature sensor (p/n HH57AC080), **STOP**. You do not need to continue with this section.

- Turn off power to the unit and install Lockout Tag.
- Depending on the type of panels the unit is equipped with:
 - Units with standard panels —
Remove the EconomiSer hood from the base unit and save the screws for Step 9a.
 - Units with factory-installed hinged panels—
Open the hinged panel and secure it. Since the panel is hinged, do not remove it from the unit.
- Disconnect the black and red wires from the pre-existing single enthalpy sensor (p/n HH57AC078) and let them hang. Remove the single enthalpy sensor and save the screws (no. 8) for use in Step 4. The wires will be used later to connect to the enthalpy sensor.
- Use the two sheet metal screw (no. 8) from Step 3 to mount the dry bulb sensor on the front left of the EconomiSer from, as shown in Fig. 1 and 2. Use the two screw holes in the EconomiSer frame.
- Ensure the black and red wires are connected on the EconomiSer IV controller correctly. The red wire should be connected to the “SO” terminal and the black wire to the “SO+” terminal. If they are not connected this way, make the connections as described. The CRTEMPSN002A00 kit contains an extra red and black wire.

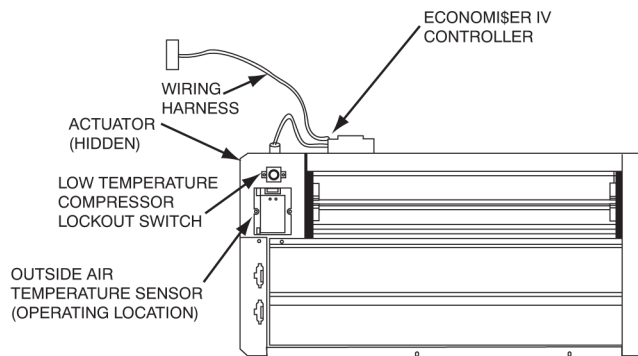

C07367

Fig. 1 - EconomiSer IV Component Locations

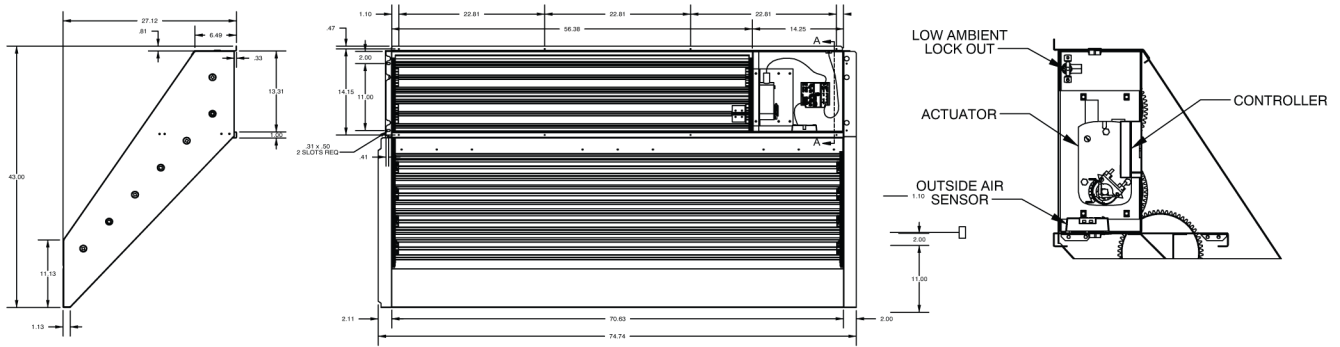
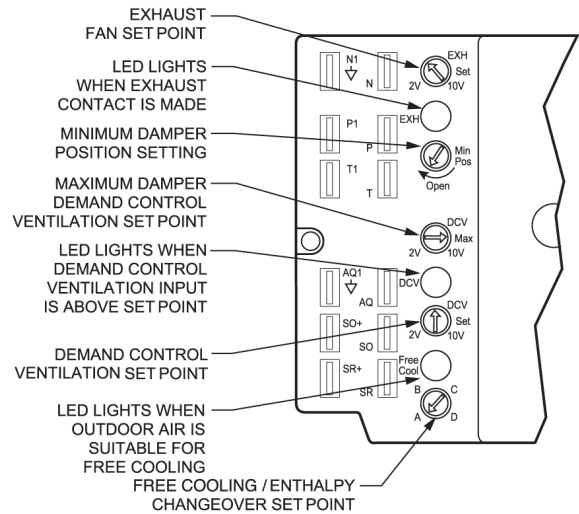

Fig. 2 - Location of Sensor

C10341

6. Pick up the black and red wires left hanging in Step 3 and connect them to the temperature sensor. Connect the red wire to the sensor's "-" terminal and the black wire to the sensor's "+" terminal. See fig. 3 for details.
7. Restore power to the unit and configure the EconomiSer IV controller per the configuration section of this manual.
8. Depending on the type of panels the unit is equipped with:
 - a. Units with standard panels — re-install the EconomiSer hood. Secure the hood using the screws saved from Step 2a.
 - b. Units with factory-installed hinged panels — Close the hinged panel and latch it.



C07385

Fig. 4 - EconomiSer IV Controller Potentiometer and LED Locations

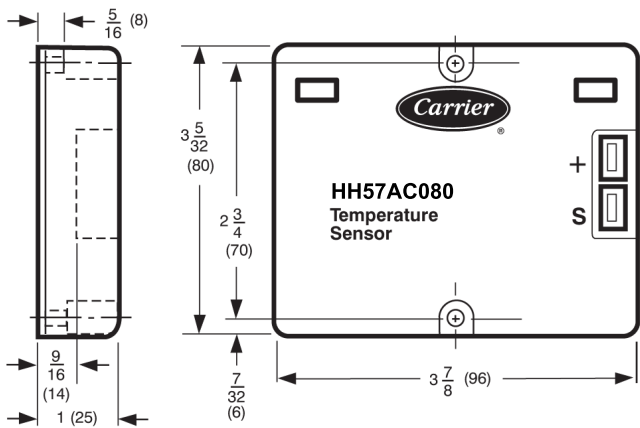

C07404

Fig. 3 - Temperature Sensor Specifications

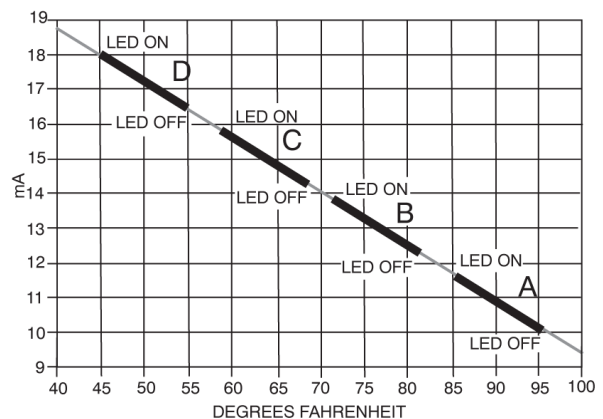

C06035

Fig. 5 - Outdoor Air Changeover Temperature

C7660 Set Up

See fig. 6.

When outdoor air temperature is below the changeover setpoint, the sensor will provide a 20 mA signal to the economizer which translates to **OK to economize** positioning the damper open on a call for cooling. When the outdoor air is above the changeover setpoint, the sensor provides a 4 mA signal to the economizer which translates to **not OK to economize** and the outdoor damper drives to minimum position. The C7660 temperature sensors replace the control function of the temperature changeover in the economizer control.

The A-B-C-D potentiometer on the economizer does not control the changeover point when a C7660 sensor is used in place of an enthalpy sensor. For single dry bulb set the potentiometer to D. The factory default switch setting is 63°F. the changeover temperature can be field set by changing the positions of the switches using fig. 7.



C101070

Fig. 6 - C7660 Temperature Sensor

CONFIGURATION

Outdoor dry bulb Changeover

For this control mode, the outdoor temperature is compared to an adjustable set point selected on the control. If the outdoor air temperature is above the set point, the EconomiSer IV will adjust the outdoor air dampers to minimum position. If the outdoor air temperature is below the set point, the position of the outdoor air dampers will be controlled to provide free cooling using outdoor air. When in this mode, the LED next to the free cooling set point potentiometer will be on.

Outdoor Air Sensor

The C7660 Dry Bulb has three dip switches that are used to set the change over temperature to meet the application. The factory default setting is 63°F. there are two changeover strategies available: exclusive operation where you can have either mechanical cooling or economizer but not both simultaneously (Single Stage Thermostat) or integrated operation, where the economizer and mechanical cooling can operate simultaneously, requires the use of a two stage thermostat.

Fig. 7 lists the changeover switch set point. With the power off, set the

DIP SWITCH POSITION	CHANGEOVER TEMPERATURE
ON OFF 1 2 3	48°F
ON OFF 1 2 3	53°F
ON OFF 1 2 3	55°F
ON OFF 1 2 3	58°F
ON OFF 1 2 3	63°F
ON OFF 1 2 3	68°F
ON OFF 1 2 3	73°F
ON OFF 1 2 3	78°F

Fig. 7 - Changeover Switch Set Points

switches to the appropriate temperature required for application. Set the free Cooling/Enthalpy Changeover Set Point potentiometer to "D" located on the face the economizer control.