

# SMMS-e Single VRF Outdoor Unit MMY-MAP1686HT6P-UL - Heat Pump

**TOSHIBA**  
*Carrier*

## Submittal Data

Job Data \_\_\_\_\_ Location \_\_\_\_\_  
 Buyer \_\_\_\_\_ Buyer PO # \_\_\_\_\_ Carrier # \_\_\_\_\_  
 Unit Number \_\_\_\_\_ Model Number \_\_\_\_\_  
 Performance Data Certified By \_\_\_\_\_ Date \_\_\_\_\_



### SMMS-e VRF Heat Pump Features

- 6, 8, 10, 12, & 14 ton modules are available.
- Modules have 2 inverter-driven twin rotary compressor.
- Backup capability due to multiple compressors
- Compressor speed varied in 0.1 Hz increments for comfort and efficiency
- Direct drive, inverter-driven 64-step outdoor motor
- Modules can be combined to form larger systems up to 38 tons.
- 985 ft (300 m) actual total system piping (liquid line)
- Up to 330 ft (100 m) control wiring between outdoor units
- 623 ft (190 m) actual piping length from outdoor unit to furthest fan coil
- Up to 6560 ft (2000 m) control wiring between the outdoor unit and indoor units
- Operating temperature range  
Cooling (db): 14 to 122 F (-10 to 50 C)  
Heating (wb): -13 to 60 F (-25 to 15.6 C)
- Protection: high pressure switch, low pressure sensor and switch, process controller board fuse, inverter overload protection
- 7-year compressor limited warranty, 5-year parts limited warranty

Header Unit Model	MMY-MAP1686HT6P	
<b>PERFORMANCE</b>		
Nominal Cooling Capacity	Btu/h	168,000
Nominal Heating Capacity	Btu/h	189,000
Maximum Total Connected Indoor Unit Capacity*		Up to 150%
<b>COOLING EFFICIENCY†</b>		
EER/IEER, Ducted FCUs		11.20/21.00
EER/IEER, Ductless FCUs		11.00/23.80
<b>HEATING EFFICIENCY†</b>		
COP at 47 F, Ducted FCUs		3.70
COP at 47 F, Ductless FCUs		3.74
Fan Type (Qty)		Propeller (2)
Airflow, Standard Range	CFM	10080
Sound Pressure, Cooling/Heating	dBA	64/65
External Static Pressure**	in. wg	0.16
<b>ELECTRICAL</b>		
Power Supply	V/Ph/Hz	460/3/60
Minimum Circuit Amps (MCA)	A	31
Recommended Fuse Size	A	35

<b>COMPRESSORS</b>		
Type (Number)	Inverter Twin Rotary (2)	
Motor Output	kW	2 x 6.5
<b>FAN MOTOR</b>		
Motor Type (Steps)	Inverter Direct Driven (64)	
Motor Output	kW	1.0 + 1.0
<b>PHYSICAL DATA</b>		
Pipe Connection Size - Liquid (High Pressure)	in.	5/8 (Flare)
Pipe Connection Size - Gas (Low Pressure)	in.	1-1/8 (Brazed)
Balance	in.	3/8 (Flare)
Refrigerant	R-410A	
Factory Charge††	lb	25.4
External Finish	Munsell 1Y8.5/0.5	
Header Unit/Follower Unit Width	in.	63
Header Unit/Follower Unit Height	in.	72-7/8
Header Unit/Follower Unit Depth	in.	30-11/16
Header Unit/Follower Unit Net Weight	lb	838

### LEGEND

**db** — Dry Bulb  
**COP** — Coefficient of Performance  
**EER** — Energy Efficiency Ratio  
**FCU** — Fan Coil Unit  
**IEER** — Integrated Energy Efficiency Ratio  
**wb** — Wet Bulb

\*When total connected indoor unit capacity exceeds 135%, number and types of indoor units are limited.  
 †Rated per AHRI (Air-Conditioning, Heating and Refrigeration Institute) 1230 Standard.  
 Cooling: Indoor 80 F (27 C) db/67 F (20 C) wb; Outdoor 95 F (35 C) db  
 Heating: Indoor 70 F (21 C) db; Outdoor 47 F (8 C) db/43 F (6 C) wb  
 \*\*Requires setting by DIP switches.  
 ††Additional charge required.  
 NOTE: Unit cabinet and coil slab shall be capable of withstanding 500-hour salt spray test in accordance with the ASTM (American Society for Testing and Materials, U.S.A.) B-117 Standard.

Manufacturer reserves the right to discontinue, or change at any time, specifications or designs without notice and without incurring obligations.

# DIMENSIONAL DRAWING

## OUTDOOR UNIT: HEAT PUMP/SINGLE UNIT MMY-MAP1686HT6P-UL

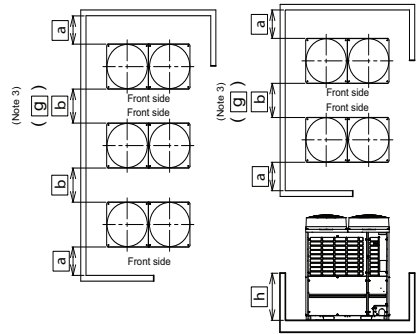
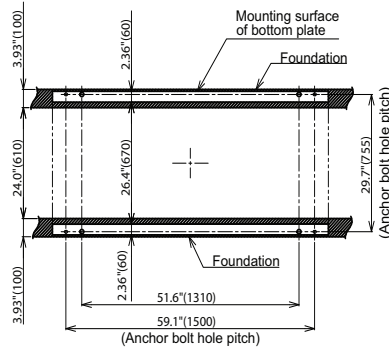
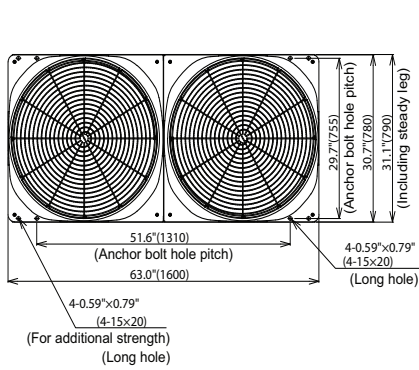

No	Parts name	Remarks
①	Balance pipe connection port	Φ3/8"(9.5)
②	Liquid pipe connection port	Φ3/4"(19.1)
③	Discharge gas pipe connection port	Φ1"(25.4)
④	Knockout hole for power wiring 1	Φ0.87"(22.2)
⑤	Knockout hole for power wiring 2	Φ1.72"(43.7)
⑥	Knockout hole for control wiring	Φ1.06"(27)
⑦	Square hole (for freight handling)	4-2.36"x7.87"(4-60x200)
⑧	Square hole (for hanging)	4-1.58"x2.17"(4-40x55)

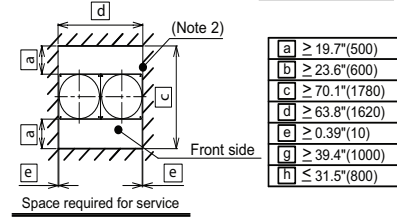
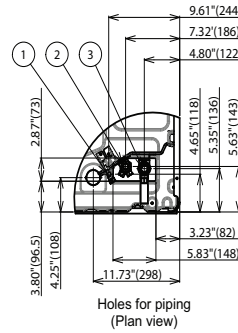
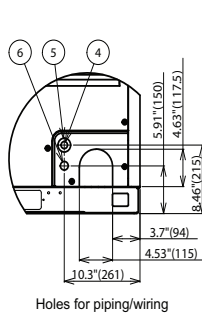

a	≥ 19.7"(500)
b	≥ 23.6"(600)
c	≥ 70.1"(1780)
d	≥ 63.8"(1620)
e	≥ 0.39"(10)
g	≥ 39.4"(1000)
h	≤ 31.5"(800)

**NOTES:**

- A minimum clearance of 78.7 in. (2000 mm) is required above the unit.
- Any wall or barrier should not exceed 31.5 in. (800 mm) from the bottom of the unit.
- The main pipe in front of the unit must extend at least a minimum of 19.7 in. (500 mm) before it can turn 90 degrees in either left or right direction.
- Dimensions in parentheses are in millimeters.

