

EXPANSION VALVE COILS

ALL MODELS

- 1½ thru 5 Tons
- Copper tube / aluminum fin "A" coil with latest high-tech fin design
- Bolt-on TXV metering device factory installed on all models (equalizer tube brazed in)
- TXV and manifold positioned to the side for easier cleaning
- Innovative drain pan design for complete water removal
- Two condensate drain connections (EDM has additional two for horizontal installation)
- 2-piece delta plate for easier removal and cleaning

CASED COILS

- Upflow cabinet widths and horizontal cabinet depths match flush with ICP gas furnaces
- Removable front access panel
- Easy slide-out coil for inspection
- Hemmed flanges for safer handling
- Foil faced insulation
- Non-sweat cabinet, even at extreme conditions
- Cabinets meet or exceed 2% air leakage codes
- Sturdy, 22 gauge, pre-painted steel cabinet

EDM

- Multiposition installation – upflow, downflow, or horizontal
- Available for R-410A or R-22 systems
- Two UV light knock-outs provided on cabinet
- Available with industry exclusive tin coated copper main tubing for additional corrosion protection

EDD

- Upflow or downflow installation
- Available for R-410A or R-22 systems
- Two UV light knock-outs provided on cabinet
- Available with industry exclusive tin coated copper main tubing for additional corrosion protection

EBU

- Value Line, upflow only, R-22 only

UNCASED A-COILS

EDA

- Upflow or downflow installation
- Available for R-410A or R-22 systems
- Available with industry exclusive tin coated copper main tubing for additional corrosion protection

EBA

- Value Line, upflow only, R-22 only



ARI Standard 210/240
Unitary Air Conditioners



ARI Standard 210/240
Unitary Heat Pumps



Rated in accordance with ARI Standard 210 and/or 240.
Certification applies only when used with proper components as listed with ARI.

Available Styles	EDM	EDD	EDA	EBU	EBA
Cased	✓	✓		✓	
Uncased			✓		✓
Horizontal Flow	✓				
Upflow	✓	✓	✓	✓	✓
Downflow	✓	✓	✓		
R-410A	✓	✓	✓		
R-22	✓	✓	✓	✓	✓
Plain Tubes	✓	✓	✓	✓	✓
Tin Coated Tubes	✓	✓	✓		

WARRANTY*

	R-410A	R-22
	Parts Limited Warranty	Parts Limited Warranty
EDM	5 year – With timely registration, an additional 5 year.	5 Year
EDD	5 year – With timely registration, an additional 5 year.	5 Year
EBU	–	5 Year
EDA	5 year – With timely registration, an additional 5 year.	5 Year
EBA	–	5 Year

* Applies to original purchaser/homeowner, some limitations may apply. See Warranty certificate for complete details.

PHYSICAL DATA

	Model Size							
	18	24	30	36	42	48F	48J, 48L	60
TXV factory installed, hard shut-off, bi-flow type for heat pump application, non-adjustable superheat								
R-22 TXV Size	3 ton				5 ton			6 ton
R-410A TXV Size	2 ton		3 ton	4 ton	5 ton			
TXV Connections	TXV-to-coil = Bolt-on 3/4-20 UNF straight thread (factory assembled)							
	field line set to TXV = 3/8" sweat (female)							
	equalizer-to-coil = brazed in (factory brazed)							
Nominal Acceptable CFM Range								
CFM – min	525	700	875	1050	1225	1400	1750	
CFM – max	625	900	1125	1350	1600	1800	2000	
Coil Data (all coils 2 slab "A" configuration, lanced sine wave bare aluminum fin)								
Face Area (ft ²)	2.75	3.67	4.58	5.04	5.50	6.42	5.50	6.88
Each Slab H x W (in)	12 x 16½	16 x 16½	20 x 16½	22 x 16½	24 x 16½	28 x 16½	24 x 16½	30 x 16½
Fins Per Inch	17	17	16	15	15	12		13
Refrigerant Line Connections (sweat)								
Liquid (inch)	3/8	3/8	3/8	3/8	3/8	3/8		3/8
Suction (inch)	5/8	5/8	3/4	3/4	7/8	7/8		7/8

ACCESSORIES

Description	Part Number	Use with models	
		EDA, EBA	EDM, EDD, EBU
Fossil Fuel Kit	AXWR01DFC	ALL	ALL
Sub-Base (use when cased coil is mounted beneath a downflow gas or oil furnace on a combustible floor)	NAHH004SB	–	B models (15¾" wide)
	NAHH005SB	–	F models (19⅜" wide)
	NAHH006SB	–	J models (23" wide)
	NAHH009SB	–	L models (24⅝" wide)
Coil Adapter for Downflow Furnaces (when used with multiposition furnace in downflow application)	NAHA001CA	–	ALL
PVC Condensate Trap Kit (box of 50)	EBAC01CTK	ALL	ALL

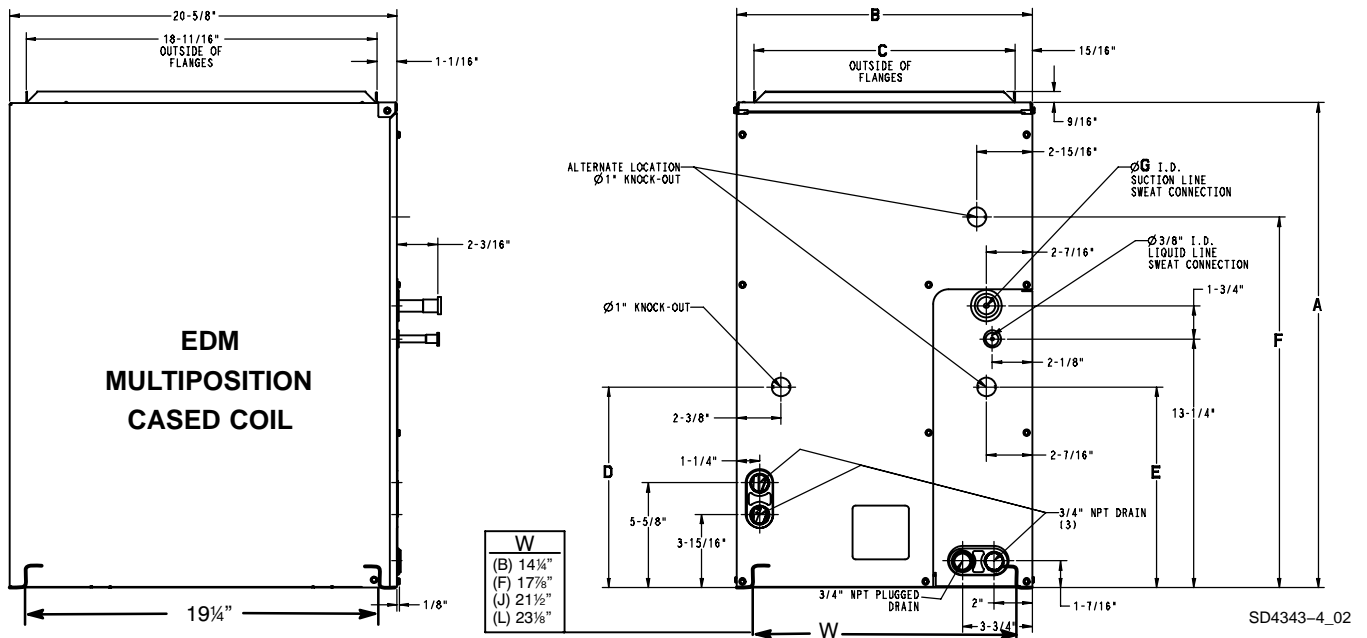

DIMENSIONAL DATA – EDM (refer to drawing at top of chart)													
Model		Size (tons)	All Dimensions Inches									Shipping Weight (lbs)	
			A	B	C	D	E	F	G	A model	AT model		
EDM	4X 2X 18B A AT	1½	25⅞	15⅝	13⅞	10⅞	10⅞	–	5/8	54.0	55.5		
EDM	4X 2X 24B A AT	2	25⅞	15⅝	13⅞	10⅞	10⅞	–	5/8	56.0	56.5		
EDM	4X 2X 24F A AT	2	25⅞	19¼	17½	10⅞	10⅞	–	5/8	59.5	60.0		
EDM	4X 2X 30B A AT	2½	25⅞	15⅝	13⅞	19¾	–	19¾	3/4	58.5	60.0		
EDM	4X 2X 30F A AT	2½	29¾	19¼	17½	10⅞	–	19¾	3/4	62.0	64.0		
EDM	4X 2X 36B A AT	3	29¾	15⅝	13⅞	19¾	–	19¾	3/4	64.0	66.0		
EDM	4X 2X 36F A AT	3	29¾	19¼	17½	19¾	–	19¾	3/4	69.5	72.5		
EDM	4X 2X 36J A AT	3	29¾	22⅞	21⅞	19¾	–	19¾	3/4	75.5	77.0		
EDM	4X 2X 42F A AT	3½	29¾	19¼	17½	19¾	–	19¾	7/8	75.0	77.0		
EDM	4X 2X 42J A AT	3½	29¾	22⅞	21⅞	19¾	–	19¾	7/8	76.0	78.5		
EDM	4X 2X 42L A AT	3½	29¾	24½	22¾	19¾	–	19¾	7/8	77.5	80.5		
EDM	4X 2X 48F A AT	4	35	19¼	17½	19¾	–	19¾	7/8	89.0	93.0		
EDM	4X 2X 48J A AT	4	29¾	22⅞	21⅞	19¾	–	19¾	7/8	83.0	86.0		
EDM	4X 2X 48L A AT	4	29¾	24½	22¾	19¾	–	19¾	7/8	84.5	87.3		
EDM	4X 2X 60J A AT	5	35	22⅞	21⅞	19¾	–	19¾	7/8	88.0	91.0		
EDM	4X 2X 60L A AT	5	35	24½	22¾	19¾	–	19¾	7/8	97.0	100.0		

Specifications subject to change without notice.

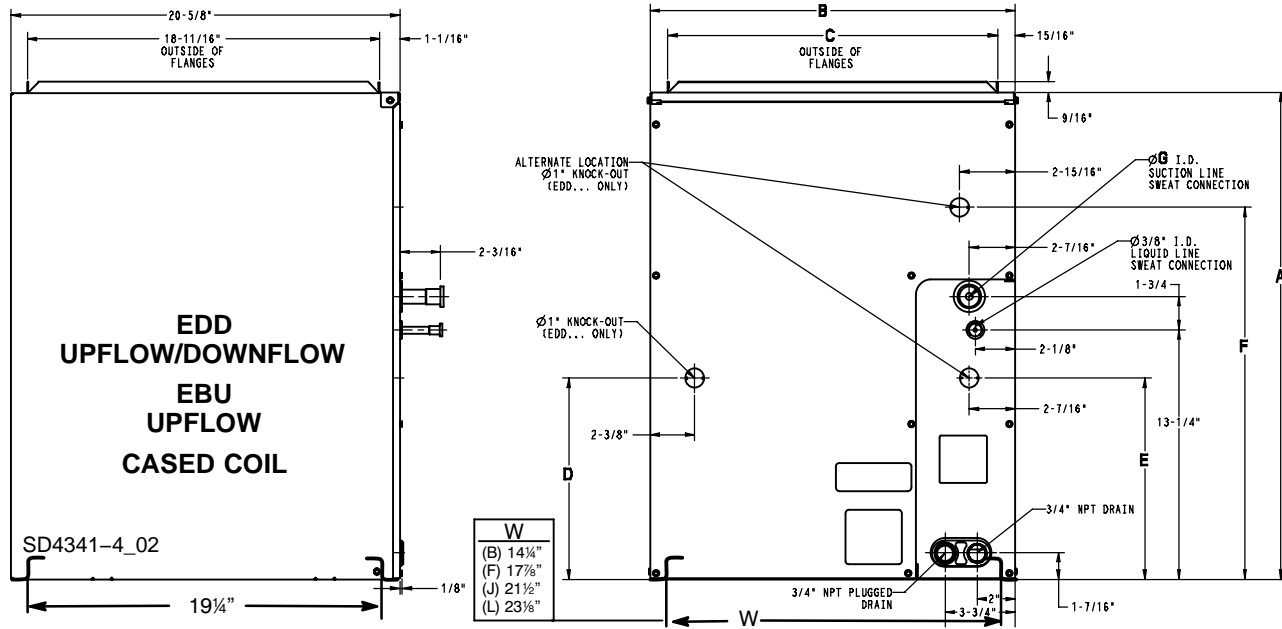

DIMENSIONAL DATA – EDD, EBU (refer to drawing at top of chart)

Model	Size (tons)	All Dimensions Inches								Shipping Weight (lbs)	
		A	B	C	D	E	F	G	A model	AT model	
EDD 2X 18B A 4X 18B AT	1 1/2	18 5/16	15 5/8	13 7/8	10 11/16	10 11/16	-	5/8	38.5	40.5	
EBU 2X 18B A											
EDD 2X 24B A 4X 24B AT	2	19 9/16	15 5/8	13 7/8	10 11/16	10 11/16	-	5/8	43.0	45.0	
EBU 2X 24B A											
EDD 2X 24F A 4X 24F AT	2	19 9/16	19 1/4	17 1/2	10 11/16	10 11/16	-	5/8	46.0	48.0	
EBU 2X 24F A											
EDD 2X 30B A 4X 30B AT	2 1/2	23 11/16	15 5/8	13 7/8	19 3/4	-	19 3/4	3/4	49.5	52.0	
EBU 2X 30B A											
EDD 2X 30F A 4X 30F AT	2 1/2	23 11/16	19 1/4	17 1/2	19 3/4	-	19 3/4	3/4	56.0	58.5	
EBU 2X 30F A											
EDD 2X 36B A 4X 36B AT	3	25 13/16	15 5/8	13 7/8	10 11/16	-	19 3/4	3/4	57.0	59.5	
EBU 2X 36B A											
EDD 2X 36F A 4X 36F AT	3	25 13/16	19 1/4	17 1/2	10 11/16	-	19 3/4	3/4	58.5	61.0	
EBU 2X 36F A											
EDD 2X 36J A 4X 36J AT	3	25 13/16	22 7/8	21 1/8	19 3/4	-	19 3/4	3/4	61.0	63.5	
EBU 2X 36J A											
EDD 2X 42F A 4X 42F AT	3 1/2	27 9/16	19 1/4	17 1/2	19 3/4	-	19 3/4	7/8	67.5	70.0	
EBU 2X 42F A											
EDD 2X 42J A 4X 42J AT	3 1/2	27 9/16	22 7/8	21 1/8	19 3/4	-	19 3/4	7/8	65.0	67.5	
EBU 2X 42J A											

(continued on next page)

DIMENSIONAL DATA (continued) – EDD, EBU (refer to drawing at top of chart)												
Model	Size (tons)	All Dimensions Inches									Shipping Weight (lbs)	
		A	B	C	D	E	F	G	A model	AT model		
EDD 2X 42L A	3½	27 ⁹ / ₁₆	24½	22 ³ / ₄	19 ³ / ₄	–	19 ³ / ₄	7/8	67.5	70.0	A	AT
EDD 4X 42L AT												
EBU 2X 42L A	4	33 ⁵ / ₁₆	19¼	17½	19 ³ / ₄	–	19 ³ / ₄	7/8	73.0	76.0	A	AT
EDD 2X 48F A												
EDD 4X 48F AT	4	27 ⁹ / ₁₆	22 ⁷ / ₈	21 ¹ / ₈	19 ³ / ₄	–	19 ³ / ₄	7/8	76.0	79.0	A	AT
EBU 2X 48F A												
EDD 2X 48J A	4	27 ⁹ / ₁₆	24½	22 ³ / ₄	19 ³ / ₄	–	19 ³ / ₄	7/8	83.0	86.0	A	AT
EDD 4X 48J AT												
EBU 2X 48J A	5	33 ⁵ / ₁₆	22 ⁷ / ₈	21 ¹ / ₈	19 ³ / ₄	–	19 ³ / ₄	7/8	88.0	91.0	A	AT
EDD 2X 60J A												
EDD 4X 60J AT	5	33 ⁵ / ₁₆	24½	22 ³ / ₄	19 ³ / ₄	–	19 ³ / ₄	7/8	93.0	96.0	A	AT
EBU 2X 60L A												

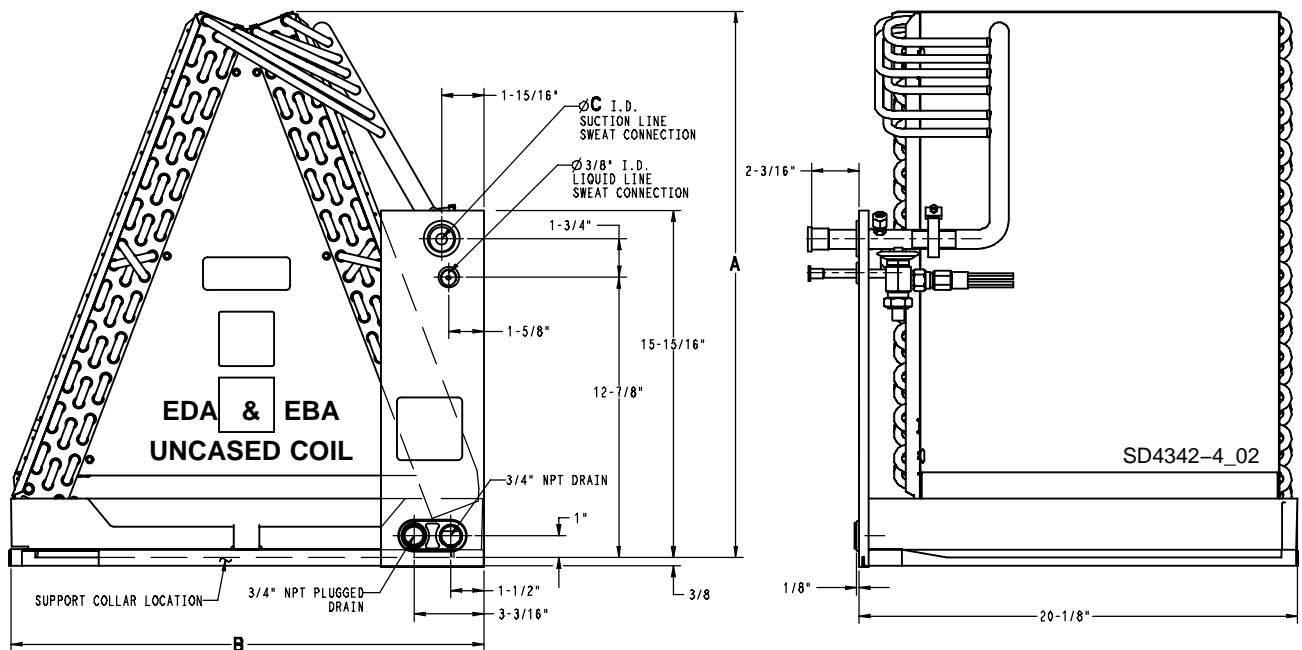

DIMENSIONAL DATA – EDA, EBA (refer to drawing at top of chart)						
Model	Size (tons)	All Dimensions Inches			Shipping Weight (lbs)	
		A	B	C	A model	AT model
EDA 4X 18B A	1½	13 ³ / ₈	14 ⁷ / ₁₆	5/8	24.5	25.5
EDA 2X 18B AT						
EBU 2X 18B A	2	17 ⁹ / ₁₆	14 ⁷ / ₁₆	5/8	29.0	30.0
EDA 4X 24B A						
EDA 2X 24B AT	2	17 ⁹ / ₁₆	14 ⁷ / ₁₆	5/8	29.0	30.0
EBU 2X 24B A						

(continued on next page)

Specifications subject to change without notice.

DIMENSIONAL DATA (continued) – EDA, EBA (refer to drawing at top of chart)									
Model				Size (tons)	All Dimensions Inches			Shipping Weight (lbs)	
					A	B	C	A model	AT model
EDA	4X	24F	A	2	16 ¹⁵ / ₁₆	18 ¹ / ₁₆	5/8	30.0	31.0
	2X	A	AT						
EBA	2X	24F	A						
EDA	4X	30B	A	2½	21¾	14 ⁷ / ₁₆	¾	32.0	33.0
	2X	A	AT						
EBA	2X	30B	A						
EDA	4X	30F	A	2½	21 ³ / ₁₆	18 ¹ / ₁₆	¾	34.5	35.4
	2X	A	AT						
EBA	2X	30F	A						
EDA	4X	36B	A	3	23¾	14 ⁷ / ₁₆	¾	35.0	36.0
	2X	A	AT						
EBA	2X	36B	A						
EDA	4X	36F	A	3	23¾	18 ¹ / ₁₆	¾	37.5	39.5
	2X	A	AT						
EBA	2X	36F	A						
EDA	4X	36J	A	3	22 ⁵ / ₈	21 ¹¹ / ₁₆	¾	38.0	40.0
	2X	A	AT						
EBA	2X	36J	A						
EDA	4X	42F	A	3½	25 ⁵ / ₁₆	18 ¹ / ₁₆	7/8	40.5	42.5
	2X	A	AT						
EBA	2X	42F	A						
EDA	4X	42J	A	3½	24¾	21 ¹¹ / ₁₆	7/8	40.5	42.5
	2X	A	AT						
EBA	2X	42J	A						
EDA	4X	42L	A	3½	24½	23 ⁵ / ₁₆	7/8	42.5	45.0
	2X	A	AT						
EBA	2X	42L	A						
EDA	4X	48F	A	4	29 ¹¹ / ₁₆	18 ¹ / ₁₆	7/8	50.0	53.0
	2X	A	AT						
EBA	2X	48F	A						
EDA	4X	48J	A	4	25 ¹ / ₁₆	21 ¹¹ / ₁₆	7/8	52.0	55.0
	2X	A	AT						
EBA	2X	48J	A						
EDA	4X	48L	A	4	24 ¹³ / ₁₆	23 ⁵ / ₁₆	7/8	55.0	58.0
	2X	A	AT						
EBA	2X	48L	A						
EDA	2X	60J	A	5	31 ⁵ / ₁₆	21 ¹¹ / ₁₆	7/8	58.5	61.5
	4X	A	AT						
EBA	2X	60J	A						
EDA	2X	60L	A	5	31 ¹ / ₁₆	23 ⁵ / ₁₆	7/8	62.0	65.0
	4X	A	AT						
EBA	2X	60L	A						

Static Pressure Drop Across Coil at a Given CFM								
Coil Size	CFM Across Coil	Static Pressure Drop Across Coil (Inches Water Column)		Coil Size	CFM Across Coil	Static Pressure Drop Across Coil (Inches Water Column)		
		Dry	Wet			Dry	Wet	
18B 1½ tons	500	0.096	0.106	42J 3½ tons	1200	0.129	0.137	
	600	0.127	0.140		1300	0.148	0.159	
	700	0.161	0.183		1400	0.168	0.180	
24B 2 tons	700	0.134	0.141		1500	0.189	0.203	
	800	0.166	0.176		1600	0.211	0.228	
	900	0.200	0.215		42L 3½ tons	1200	0.114	0.142
24F 2 tons	700	0.110	0.118	1300		0.130	0.161	
	800	0.134	0.146	1400		0.146	0.182	
	900	0.160	0.176	1500		0.164	0.202	
30B 2½ tons	800	0.137	0.143	1600		0.182	0.222	
	900	0.169	0.174	48F 4 tons	1400	0.250	0.263	
	1000	0.204	0.211		1500	0.284	0.297	
1100	0.241	0.251	1600		0.320	0.336		
30F 2½ tons	800	0.101	0.106		1700	0.358	0.376	
	900	0.121	0.129		1800	0.398	0.418	
	1000	0.143	0.154	48J 4 tons	1400	0.192	0.196	
36B 3 tons	1100	0.168	0.181		1500	0.219	0.225	
	1000	0.188	0.202		1600	0.245	0.253	
	1100	0.224	0.240		1700	0.273	0.283	
36F 3 tons	1200	0.262	0.281	1800	0.303	0.314		
	1300	0.303	0.325	48L 4 tons	1400	0.180	0.193	
	1400	0.349	0.374		1500	0.198	0.214	
	36J 3 tons	1000	0.133		0.139	1600	0.222	0.241
		1100	0.154		0.163	1700	0.247	0.270
1200		0.177	0.189	1800	0.275	0.296		
1300		0.203	0.216	60J 5 tons	1700	0.260	0.285	
1400		0.227	0.245		1800	0.288	0.315	
1000	0.104	0.106	1900		0.316	0.346		
42F 3½ tons	1100	0.121	0.124	2000	0.347	0.381		
	1200	0.139	0.144	60L 5 tons	1700	0.232	0.263	
	1300	0.159	0.166		1800	0.256	0.291	
	1400	0.181	0.190		1900	0.283	0.321	
	1200	0.180	0.208		2000	0.308	0.354	
42F 3½ tons	1300	0.201	0.231					
	1400	0.228	0.275					
	1500	0.267	0.314					
	1600	0.291	0.348					

COIL MODEL NUMBER IDENTIFICATION GUIDE													
	E	D	M	2	X	18	B	A	1				
E = Evaporator		TYPE											
D = Deluxe													
B = Builder (Value Line)													
M = Cased, Multiposition		APPLICATION											
D = Cased Upflow / Downflow													
U = Cased Upflow Only													
A = Uncased													
2 = R-22		REFRIGERANT											
4 = Environmentally Sound R-410A													
X = TXV		METERING DEVICE											
18 = 18,000 BTUH = 1½ tons													
24 = 24,000 BTUH = 2 tons		NOMINAL CAPACITY											
30 = 30,000 BTUH = 2½ tons													
36 = 36,000 BTUH = 3 tons													
42 = 42,000 BTUH = 3½ tons													
48 = 48,000 BTUH = 4 tons													
60 = 60,000 BTUH = 5 tons													
B = 15.5"		WIDTH (matches furnace)											
F = 19.1"													
J = 22.8"													
L = 24.5"													
A = Standard		SALES CODE / FEATURES											
AT = Tin Coated Copper Tubes for Additional Corrosion Protection													
Engineering Revision													